

Continuon™ 4U/HP

Database Server w/ RAID Management



Ordering Information Specifications

Continuon™ 4U/HP

Standard Configuration

- C0406A NEBS Compliant Platform
- IBC2601 SBC and Rear I/O
- Intel® 850MHz PIII Processor
- 256Mb ECC SDRAM
- Dual 300W AC Power Module
- Dual US Power Cords
- SCSI 36X CD-ROM
- 18GB SCA SCSI HDD
- 1.44MB Floppy Drive
- Product Manuals

Options

(Alternatives to standard configuration above unless otherwise stated)

- 512MB ECC SDRAM
- Additional IBC280x Computing Blades
- 36GB SCA SCSI Drives
- 3.5" 40GB DAT Drive
- CompactFlash up to 256MB
- 4-port 10/100 Ethernet Interface
- 8-port 10/100 Ethernet Interface
- 24+2 Layer 3 Switch

Control & Monitoring Options

IBC-2501

Chassis Management Controller, IPMI v.1.0 compliant Module.

- Red Hat Linux
- Windows 2000 Professional
- Windows 2000 Server
- Windows 2000 Advanced Server
- Windows NT4 Workstation
- Windows NT4 Server
- PPS Full I/O Hot-Swap Middleware (Win 2000 Server and AS only)

Chassis

- 4U Height
- 7" x 17" x 17.25" (hwd)/ 178 x 432 x 438 mm

IBC 2601 SBC

- Single or dual Socket 370 Microprocessor : Intel® Pentium® III FC-PGA up to 850MHz, or Intel® Celeron™ processors of 700MHz and beyond
- Intel® 440BX Chipset
- Up to 768MB of Synchronous DRAM (ECC or non-ECC)
- Pentium® III: 256K, 256-bit wide integrated L2 cache or Celeron™: 128K, 64-bit wide integrated L2 cache
- I-Bus embedded BIOS or Custom BIOS available
- Watchdog Timer
- 32-bit PMC Expansion
- CompactPCI Bus Master
- Dual 10/100BaseTx Ethernet Intel® 82559
- 69030 AGP Video with 4MB Memory
- Dual DMA/33 IDE Interface
- Optional CompactFlash
- Single PC Compatible USB port
- Floppy drive interface, up to 2 drives
- Dual 16C550 Serial Ports
- Bi-directional Parallel Port with EPP and ECP
- PS/2 Mouse Port and PS/2 Keyboard Interface
- 2-Slot (8HP) x 6U **CompactPCI®** Compliant
- **CompactPCI®** Compliant Rear I/O Board

Peripheral Processors

- IBC 2602, Mobile Pentium® III SBC
- Dual 10/100BaseTx Ethernet Intel® 82559
- 69030 AGP Video with 4MB Memory
- Optional CompactFlash or Microdrive
- Up to 512MB of Synchronous DRAM (ECC or non-ECC)
- RAID Controller Board

Backplane

- Integrated 6-slot **CompactPCI®** backplane
- Supports one or two-slot system master SBC
- 4-5 full hot-swap I/O slots
- PICMG 2.5 compliant H.110 backplane
- Additional slot for CMC in the rear (IBC-2501)

Drive Expansion

- Up to 180Gbyte 5 SCA drive array
- 38X CD-ROM and Floppy
- Optional 40GB DAT or RAID Controller

System Monitoring (Optional)

- Rear accessible PICMG 2.9 compliant CMC
- Monitor chassis temperature and voltages.

Thermal Management

- 40CFM hot-swap blower cooling for card and drive areas
- Dual 25CFM Integrated power supply fans

Power Subsystem

- Dual 300W Hot-swap N+1 power supplies
- Dual feed power inputs
- Input voltages: 90-132/180-250 VAC
- Optional -48VDC input supplies
- Output Power: +3.3V@22A, +5V@30A, +12V@11A, -12V@1A
- Combined total output of +3.3V and +5V not to exceed 160W
- Optional UK, European or IEC to IEC power cables

Operating Environment

- Temperature: 0° to 40° C
- Humidity: 5% to 85% @40°C (non-condensing)
- Shock: 2.5G @10ms
- Vibration: 0.25G @5-100Hz

Standards Compliance

- PICMG 2.0 R 3.0, PICMG 2.1 R2.0, PICMG 2.5 R1.0, PICMG 2.9 R1.0, PICMG 2.10 R1.0, PICMG 2.11 R1.0
- ESD: CE
- EMI: CE, FCC, UL/CUL
- Safety: UL/CUL,CE,CB



Continuon™ 4U/HP

Database Server w/ RAID Management

The **Continuon™ CompactPCI™** platform employs key features to meet the high availability requirements of the communication, network and server marketplace. Its unique design combines the performance through a dual Low Power processing Blade with the high serviceability achieved with the Hard drives and power supplies redundancy.

The **Continuon™ 4U/HP** system platform supports full I/O hot swap compliant with PICMG 2.1 R2.0, a 5 SCA hot-swap SCSI disk array with a Raid controller, a hot swap blower cooling design, and dual redundant hot swap power supplies.

As an option, it is equipped with a PICMG 2.9 compliant Chassis Management Controller (CMC) monitoring chassis temperature, power supply status, and voltages on the backplane. The CMC board occupies a dedicated slot above the rear I/O transition slots, with status LEDs visible on the chassis front panel.

The **Continuon™ 4U/HP** platform suites ideally for applications requiring small rack space, true multi-system clustering with high capacity data storage.

A maximum performance achieved in 4U height offering significant ongoing cost benefits for any application.

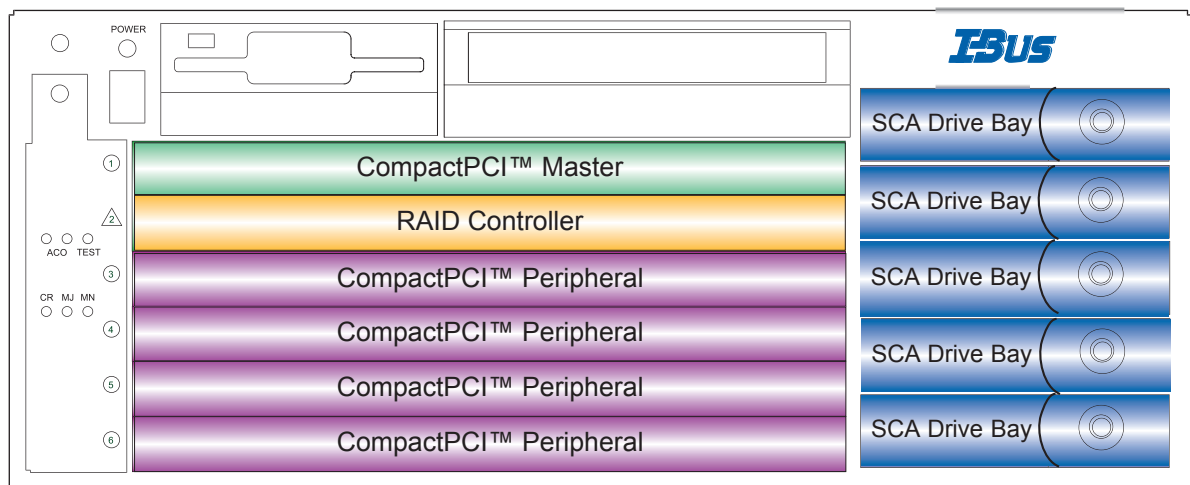

For Further Information



Worldwide Headquarters

I-Bus Corporation
 3350 Scott Blvd, Building 54
 Santa Clara, CA 95054
 United States
 Phone : +1 (408) 450-7880
 Fax : +1 (408) 450-7881
Toll Free: 877-777-IBUS
 Email: contact.us@ibus.com

European Headquarters

I-Bus UK Ltd
 Unit 6, Chichester Business Park
 City Fields Way, Tangmere
 West Sussex, PO20 2LB, UK
 Tel: +44 (0) 1243 756300
 Fax: +44 (0) 1243 756301
 Email: contact.uk@ibus.com

France, Italy

I-Bus France
 B.P 45 Valbonne
 06901 Sophia Antipolis CEDEX
 France
 Tel: +33 (0) 493 004 360
 Fax: +33 (0) 493 004 369
 Email: contact.fr@ibus.com